

Service public fédéral
Personnel et Organisation

e-Procurement

Stand van zaken op federaal niveau

Federale Dienst e-Procurement



Inhoud

- E-Procurement – een inleiding
- Huidig landschap
- Evoluties
 - Integratie van het BDA
 - E-Awarding en e-Auctions
 - Tendensen

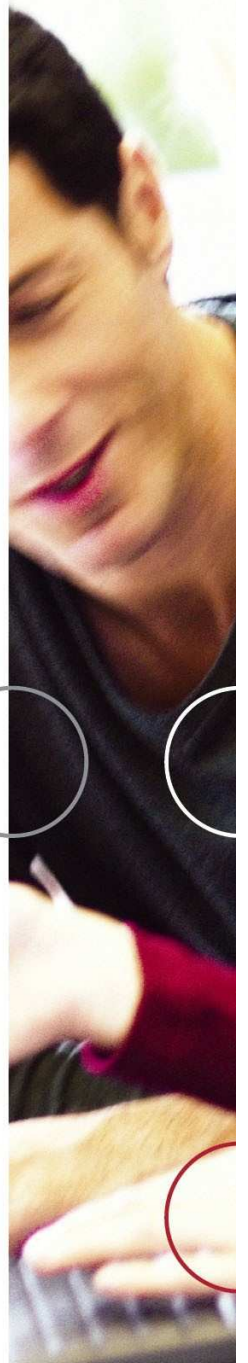
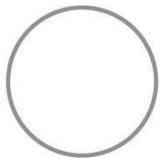
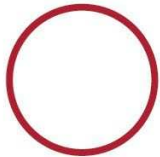



Service public fédéral
Personnel et Organisation

E-Procurement – een inleiding

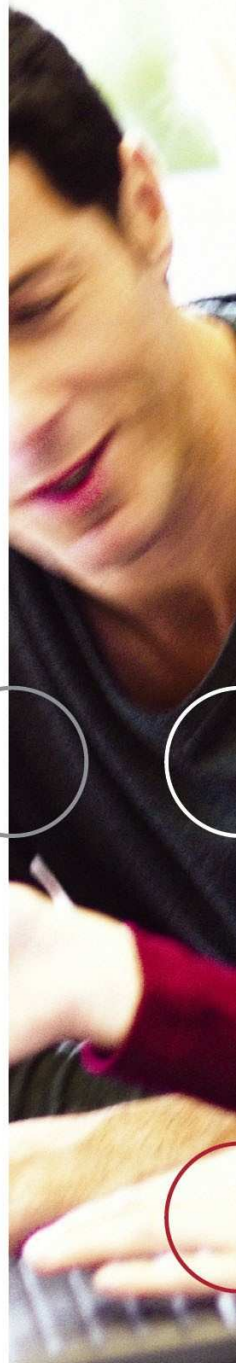
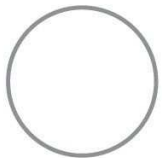

.be



Wat is e-procurement?

- Het elektronisch laten verlopen van het aankoopproces
 - Via internet
 - Front-end
- Proces
- Publicatie => gunning en beheer contract

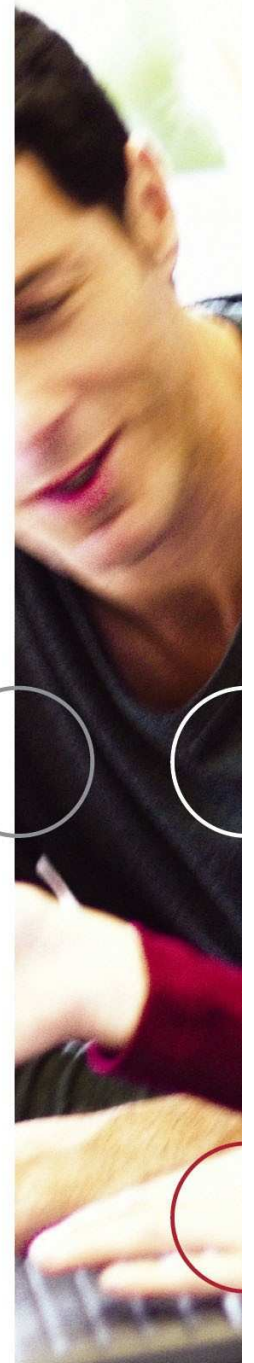
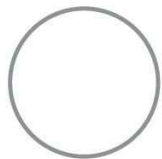



Fasen in een overheidsopdracht

- de bekendmaking;
- de indiening en de opening van kandidaturen en offertes;
- de evaluatie en de kennisgeving;
- de omgekeerde elektronische veiling (nog niet in uitvoering);
- het gebruik van catalogi;
- de facturatie en de betaling

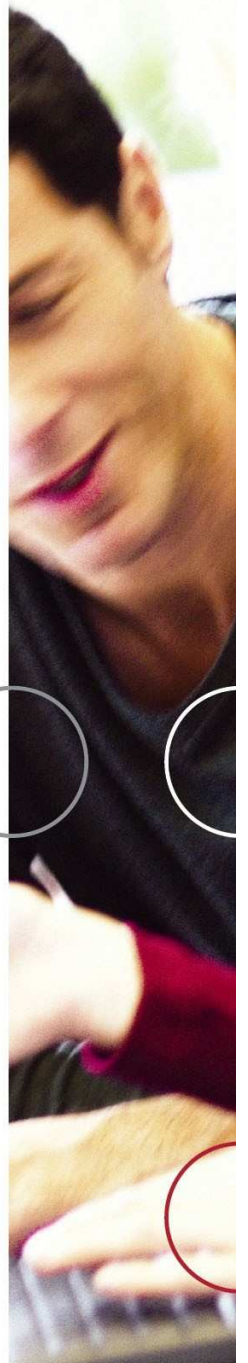
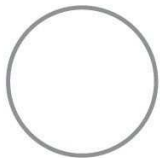



Overeenkomstige modules

De bekendmaking	➔	E-notification
Indienen en openen offertes/kandidaturen	➔	E-tendering
Evaluatie en kennisgeving	➔	E-awarding & e-notification
Omgekeerde veiling	➔	E-auction
Beheren catalogus	➔	E-catalogue
Facturatie & betaling	➔	E-invoicing & e-payment (Fedcom)

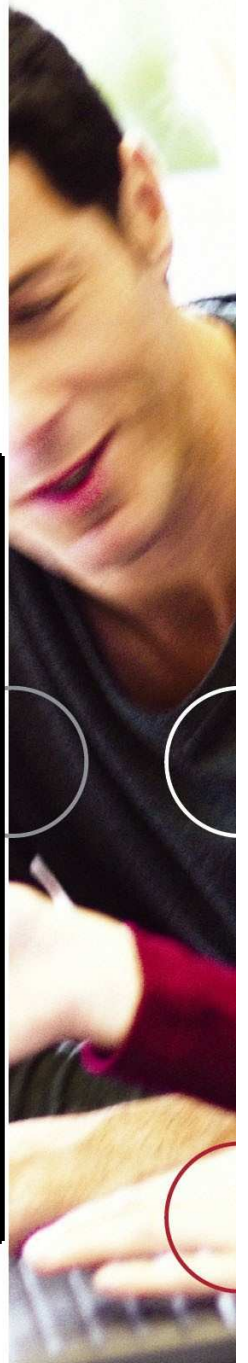



E-Notification

- Publiceren van aankondigingen naar BDA en BPEG (Europa), eventueel via workflow
- Alle 15 Europese aankondigingsformulieren worden ondersteund
- Online plaatsen van bestekken en begeleidende documenten
- Aankondigingen zoeken op basis van 20 criteria
- Ondernemingen worden automatisch geïnformeerd via een messaging-functie
- Mogelijkheid om een Q&A forum te activeren

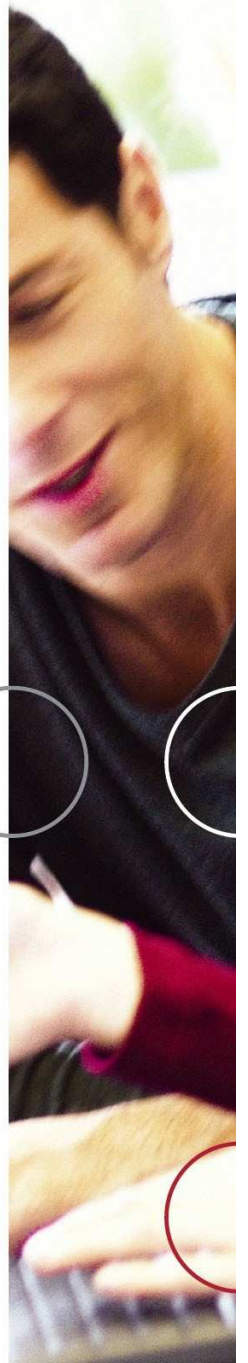
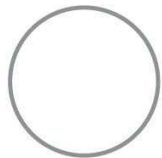



E-Tendering

- Indienen van elektronische offertes/kandidaturen (ook consortia)
- Opvragen van ontvangstbewijs
- Openen van offertes/kandidaturen
- Opstellen van PV van opening
- Downloaden van volledig dossier

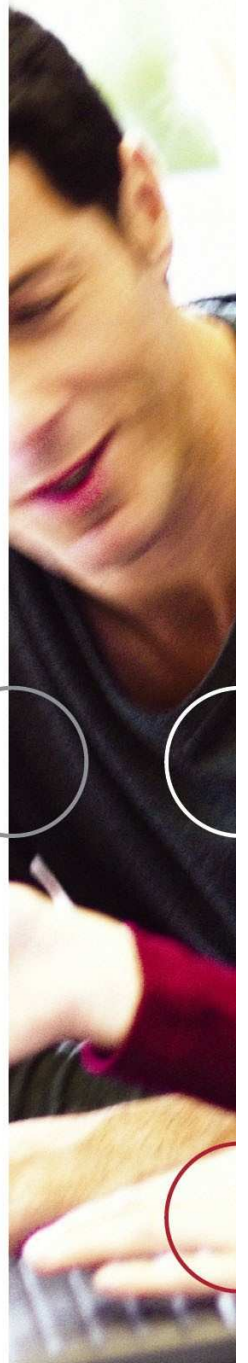
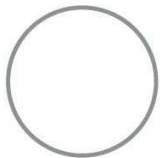
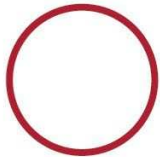



E-Catalogue

- Online plaatsen van catalogoog
 - Opladen door onderneming
 - Goedkeuren en publiceren door aanbestedende overheid
- Online plaatsen van bestellingen
 - Aankoper zoekt in catalogen
 - Aankoper stelt bestelbon op
 - Onderneming aanvaardt bestelbon
 - Keurder stelt PV van oplevering op

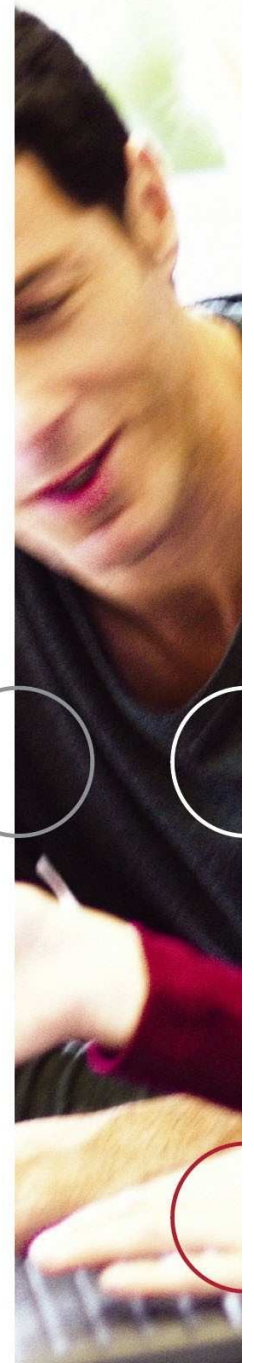
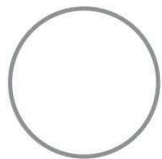
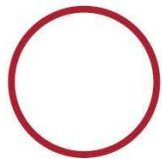



Europese doelstelling

- Europese Ministerraad van Manchester in 2006:
- Tegen eind 2010
 - Overheidsadministraties moeten in staat zijn om hun **overheidsopdrachten volledig elektronisch** te laten verlopen
 - Minstens **50%** van de opdrachten boven de Europese publicatiedrempels moeten **daadwerkelijk elektronisch** gebeuren

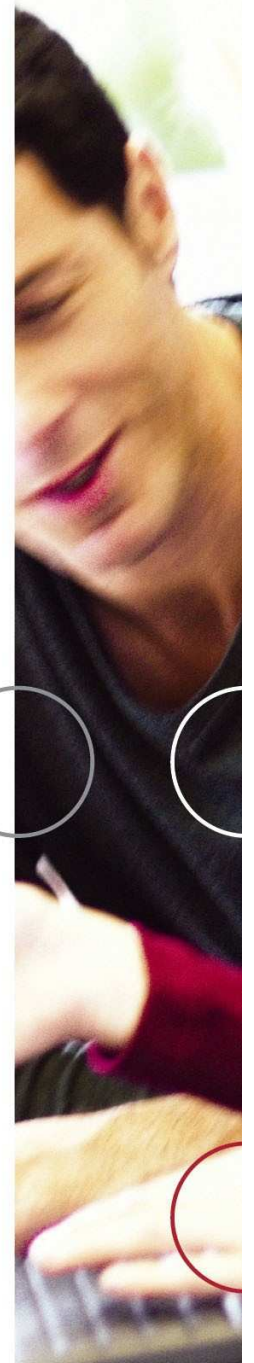
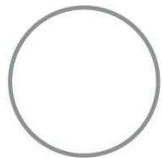



Het belang van e-procurement – voordelen overheid

- Grotere concurrentie
 - Overheidsopdrachten vormen in Europa 15 à 20% van het BNP
 - Het gebruik van e-Procurement tools moet significante besparingen opleveren
 - Uit Europese studies blijkt:
 - impact op prijs niet altijd gekend
 - Indien impact gekend: 5%
 - Impact bij veiling op prijs: 15%
- Efficiëntie aankoopproces ↑
- Conformiteit reglementering ↑
- Doeltreffendheid aankoopproces ↑



beter kopen

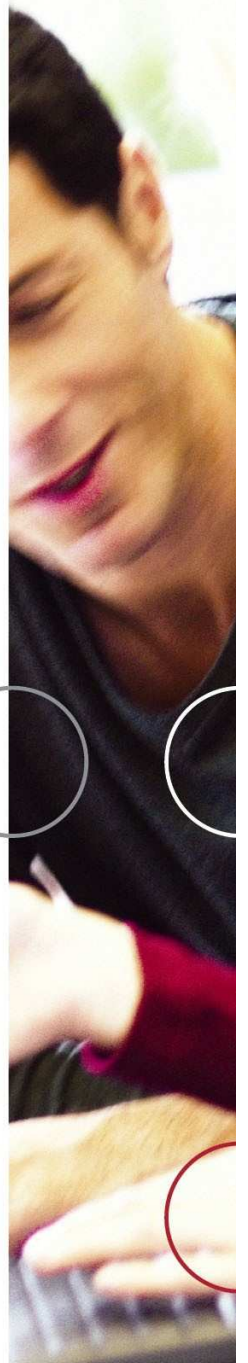



Het belang van e-procurement – voordelen ondernemingen

- Administratieve vereenvoudiging ↑
- Transparantie overheidsopdrachten ↑



beter verkopen

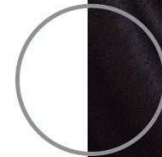
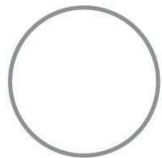



Europa – evaluatie action plan e-Procurement (2004 – 2008)

- Het aantal e-Procurement implementaties stijgt gestadig:
 - 2004: 6 lidstaten
 - 2009: 17 lidstaten
- Het gebruik van deze applicaties stijgt aanzienlijk
- Sommige fasen zijn reeds sterk geautomatiseerd
 - E-Notification
 - E-Auctions
 - Framework agreements
- Impact op prijs

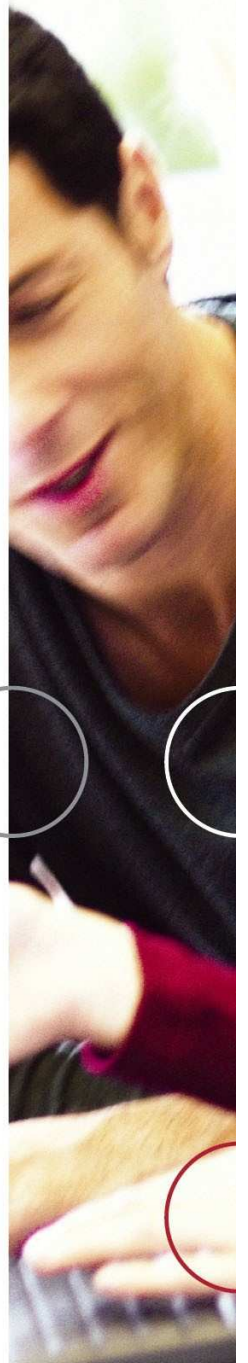
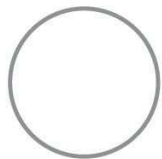



Europa – evaluatie action plan e-Procurement (2004 – 2008)

- Sommige fasen (post-award) zijn minder geautomatiseerd:
 - e-Ordering & e-Invoicing
 - e-Evaluation
- Lidstaten willen e-notices opleggen
- E-Auctions is nuttig, maar niet altijd goed begrepen
- Dynamisch Aankoopstelsel (DPS): weinig gebruikt
- Obstakels voor cross-border
 - Digitale handtekening
 - Taalaspecten
 - interoperabiliteit

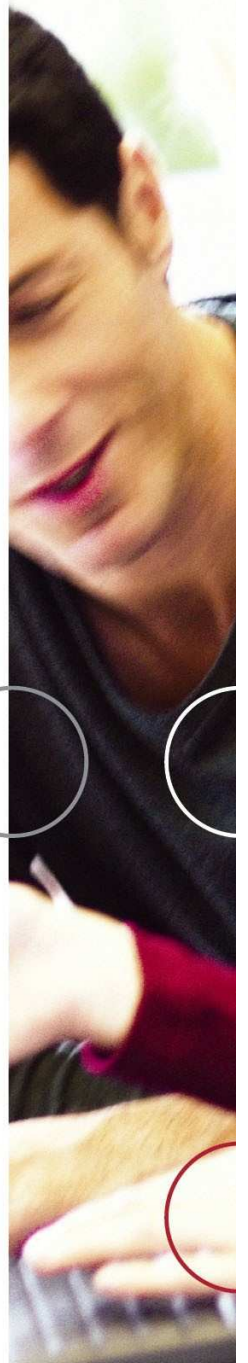



Visie dienst e-Procurement

- Customisatie bestaande producten
- Open source
- Geen licentiekosten
- Modulaire aanpak
- Evolutief onderhoud
- Correctief onderhoud
- Afsluiten van samenwerkingsprotocollen met andere overheidsniveaus

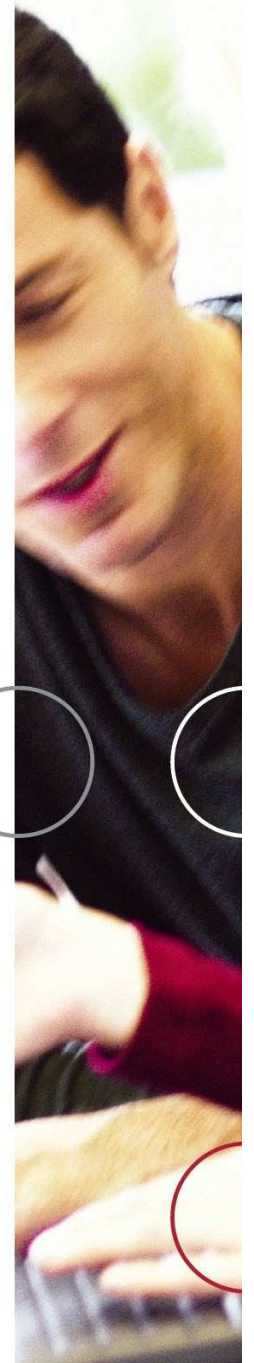
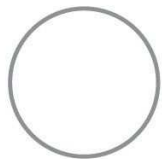
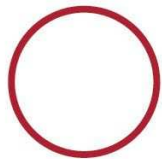



Samenwerking

- Samenwerkingsprotocollen met andere bestuursniveaus
 - Vlaamse Overheid
 - Brussels Hoofdstedelijk Gewest
 - Waals Gewest en de Franstalige Gemeenschap
- Samenwerkingsakkoorden met private ondernemingen
 - 3P
 - EBP

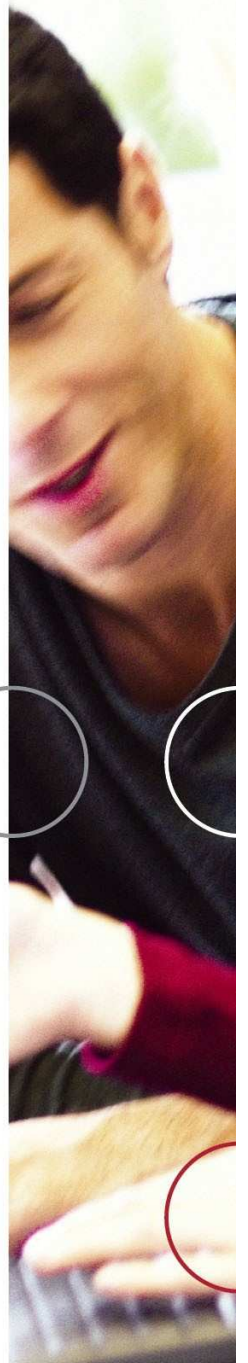
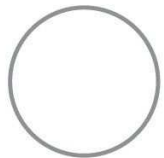
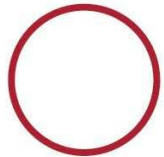



Service public fédéral
Personnel et Organisation

Huidig landschap

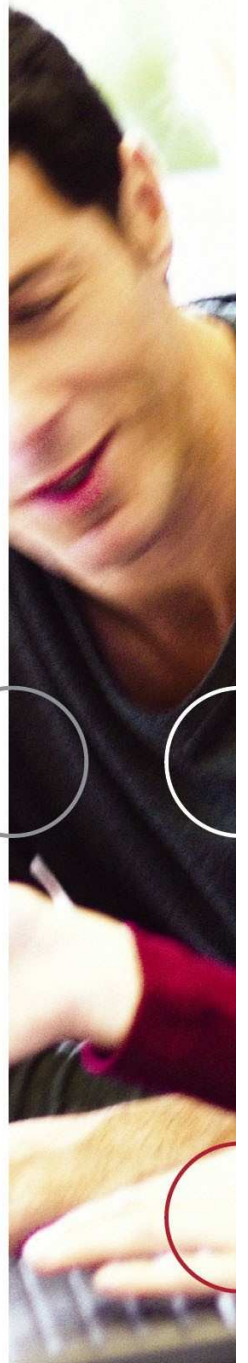
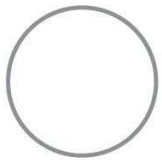

.be



Het huidige landschap

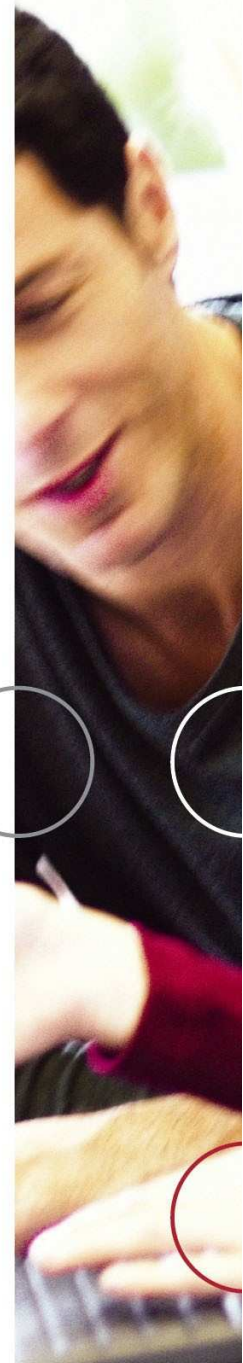
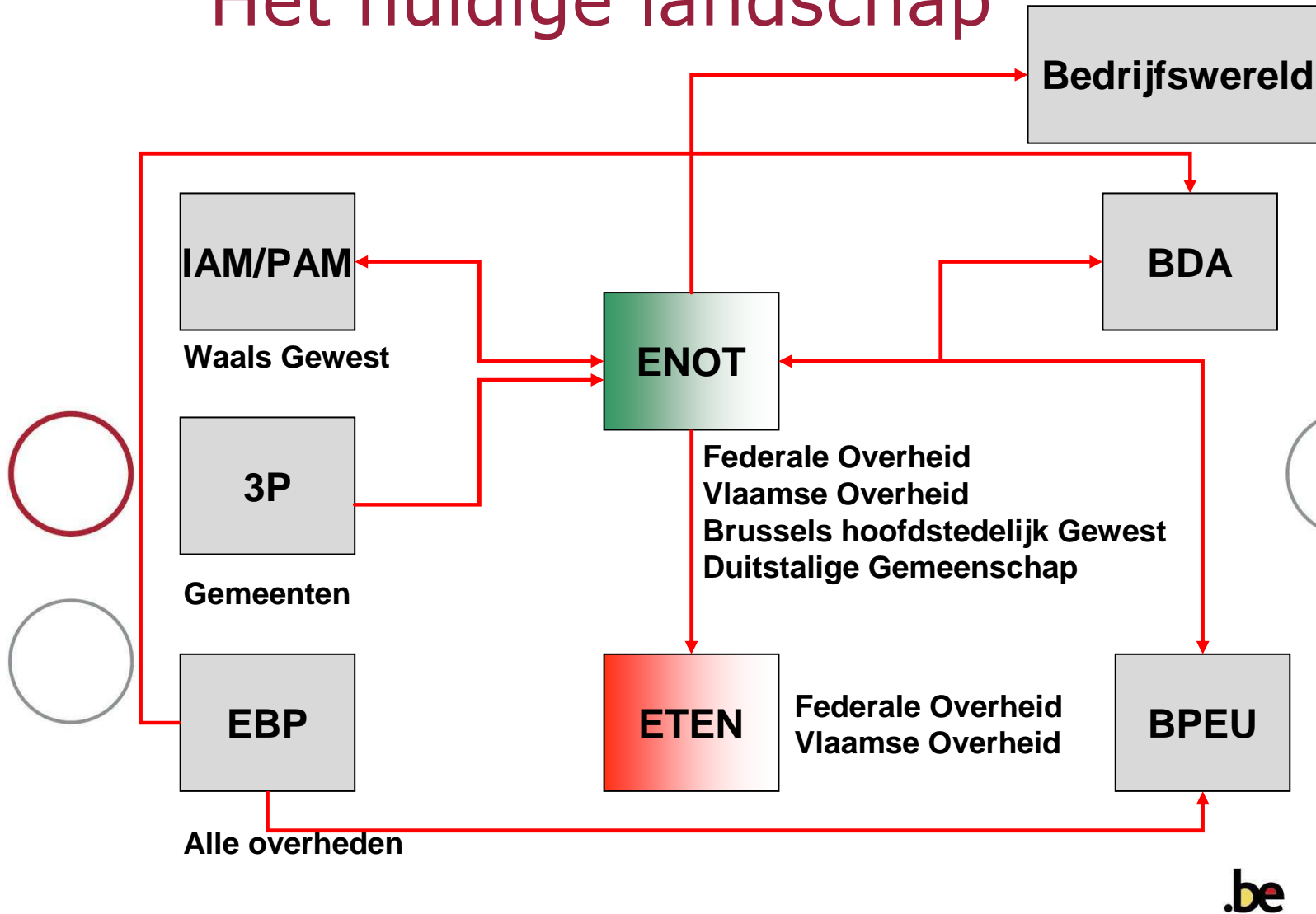



Service public fédéral
Personnel et Organisation

Evoluties

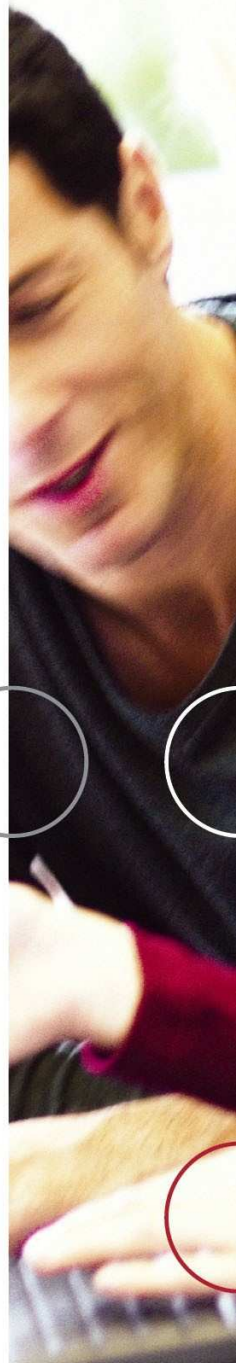
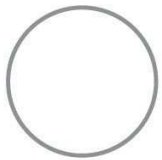

.be



Service public fédéral
Personnel et Organisation

1) Integratie van het Bulletin der Aanbestedingen

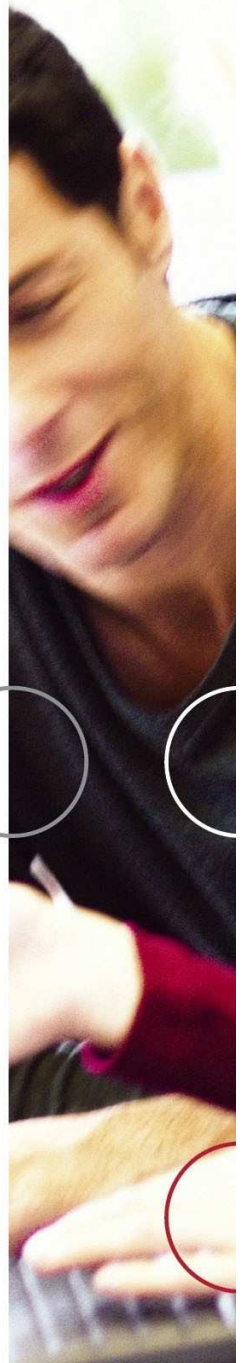
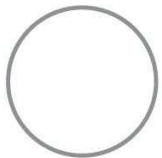

.be



Integratie van het BDA (1)

- Beslissing MR 12 maart 2010
- Officieel bericht in BS op 6 september 2010
- Vanaf 1 januari 2011
 - E-Notification = officieel nationaal publicatieplatform
- BDA (bijlage BS) blijft officieel nationaal platform van aankondigingen vóór 2011

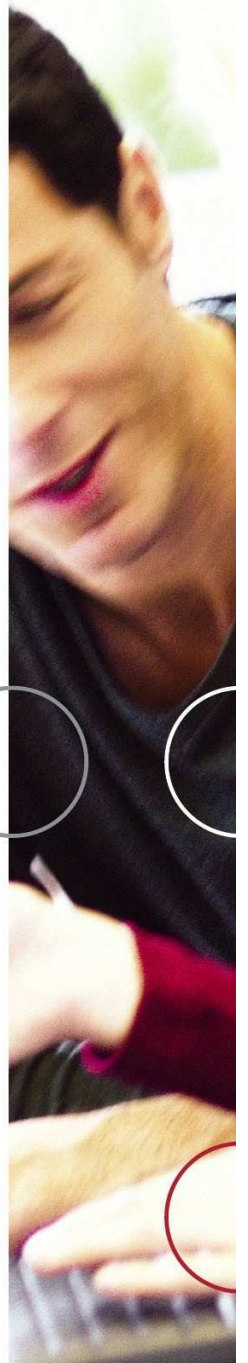
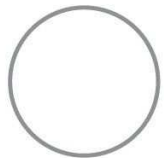
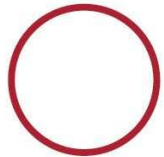



Integratie van het BDA (2)

- Manieren van publiceren
 - Online via e-Notification (**gratis**)
 - Via erkende e-sender (**gratis**)
 - Brief/fax/mail
 - **Betalend**
 - » 2.000 Euro (aankondiging)
 - » 1.000 Euro (wijzigingsbericht)
 - » 200 Euro extra (vanaf pag. 16)
 - » 2 publicatietalen: 2 x betalen
- Tot 31/12/2011
- Templates:
<http://www.publicprocurement.be>

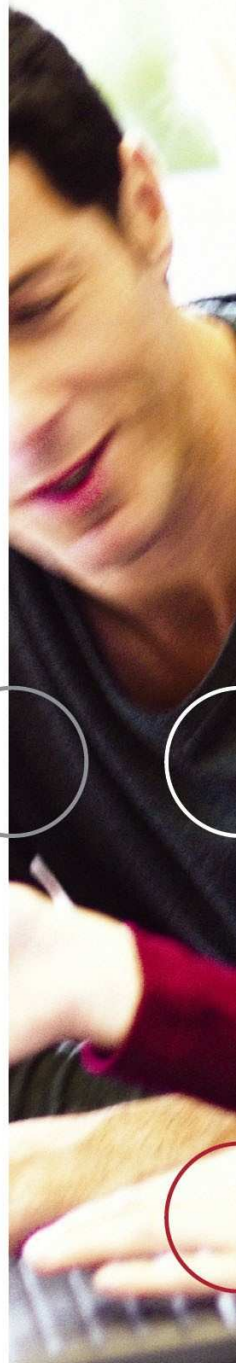



Integratie van het BDA (3)

- Ondernemingen
 - Anoniem zoeken
 - Profiel aanmaken
 - Dagelijks ontvangst van mail met matchende overheidsopdrachten
 - favorieten
- Helpdesk
 - Voor aanbestedende overheid en ondernemingen
 - gratis
 - 027905200
 - e.proc@publicprocurement.be

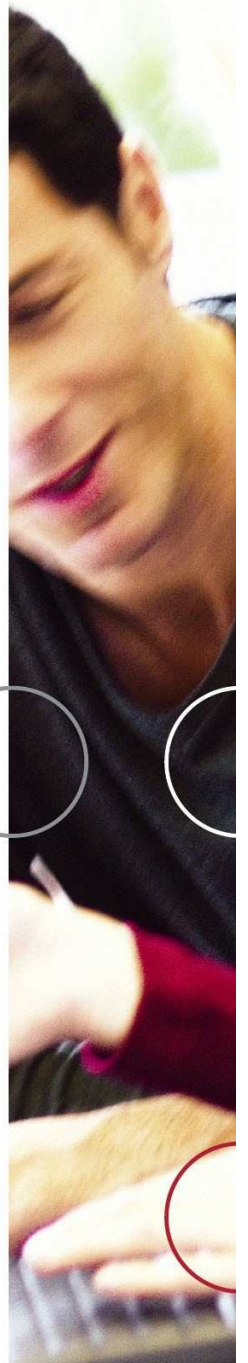
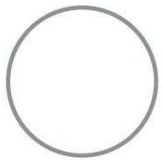



Voordelen integratie

- Één platform voor ondernemingswereld
- Één platform door overheid te onderhouden
- => win-win situatie

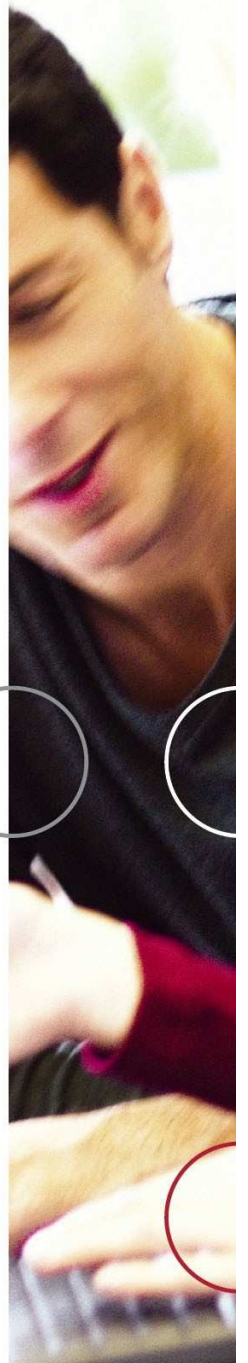
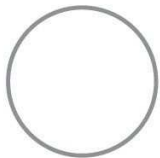



Service public fédéral
Personnel et Organisation

2) e-Awarding en e-Auctions

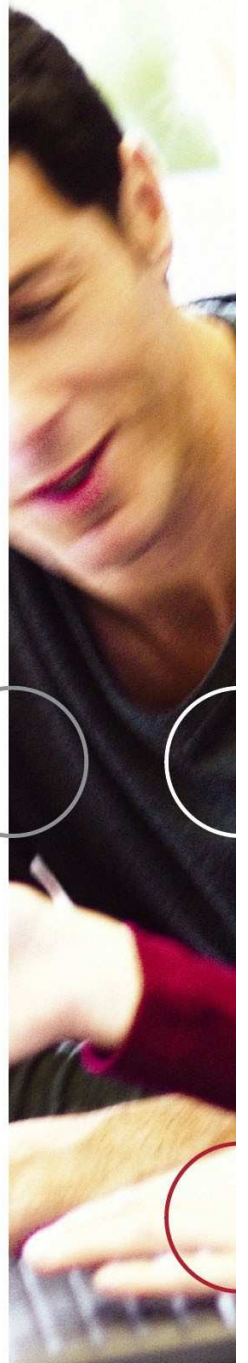
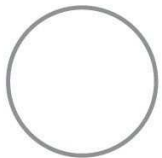

.be



E-Awarding

- Templates
- Document beheersysteem
- Dossier beheersysteem gekoppeld aan workflow
- Evaluatie op basis van gunningscriteria
- Publicatie van gegunde opdracht

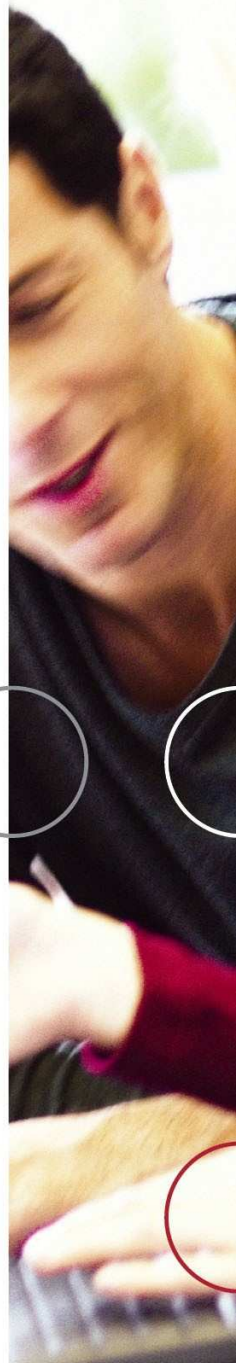
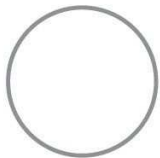



E-Auctions - reglementering

- Reglementering
 - Europese richtlijn 2004/18/EC
 - Wet van 15 juni 2006
 - KB?
- Aandachtspunten:
 - Aanbestedingen
 - Leveringen en diensten
 - Alle conforme offertes worden uitgenodigd
 - ...

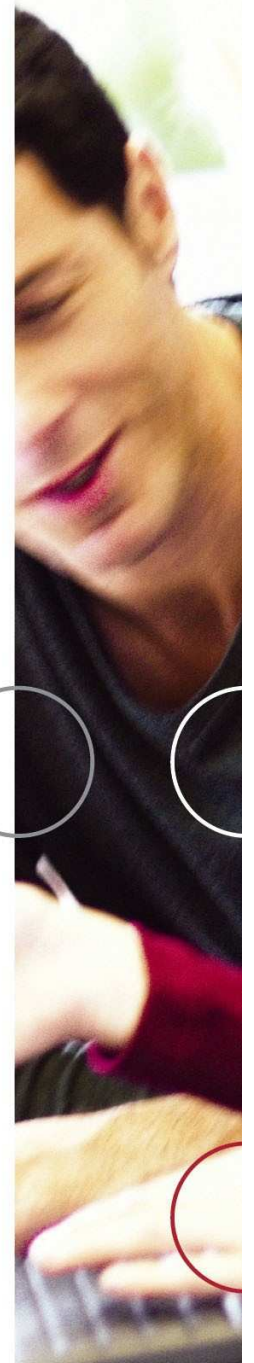
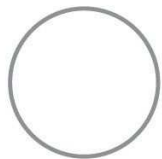

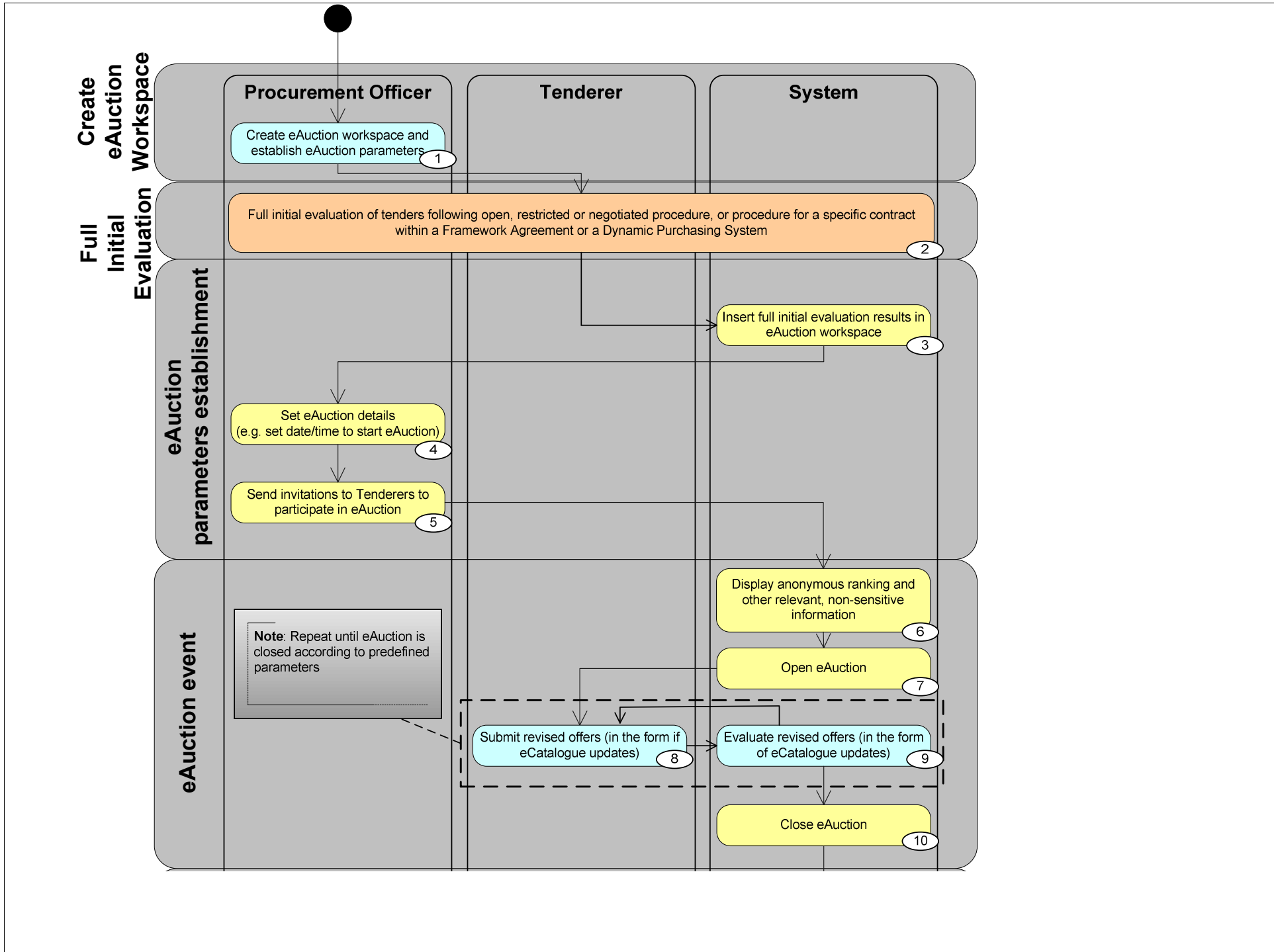



E-Auctions – verloop (2)

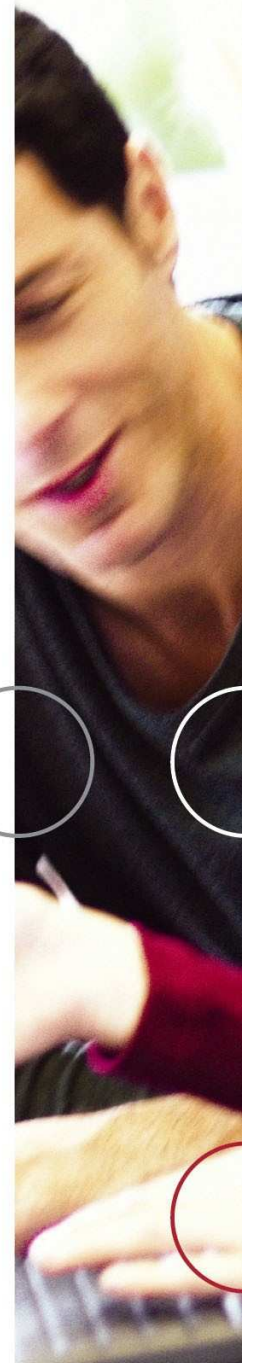
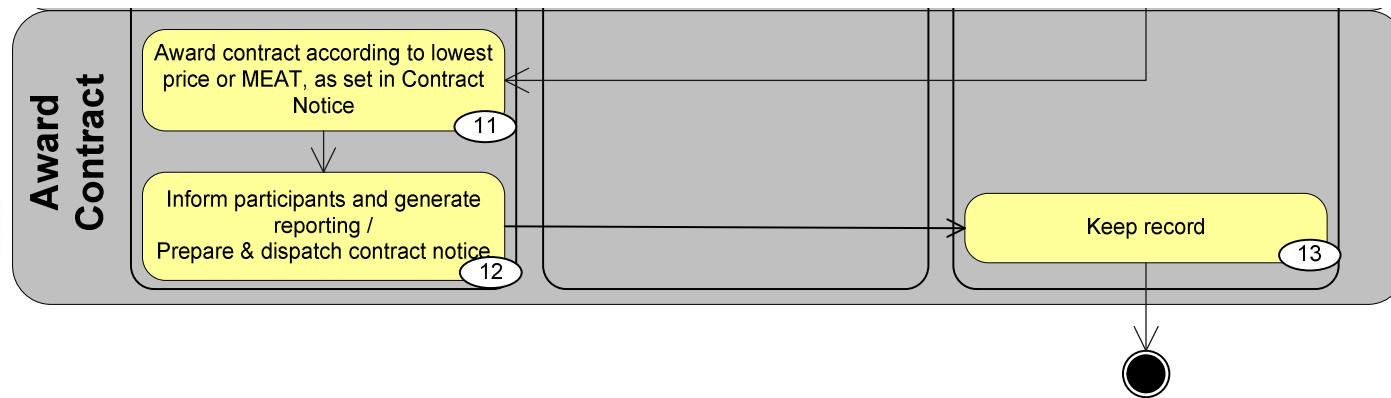
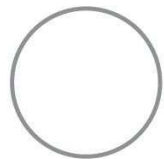
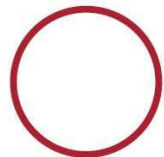



Het landschap - toekomst

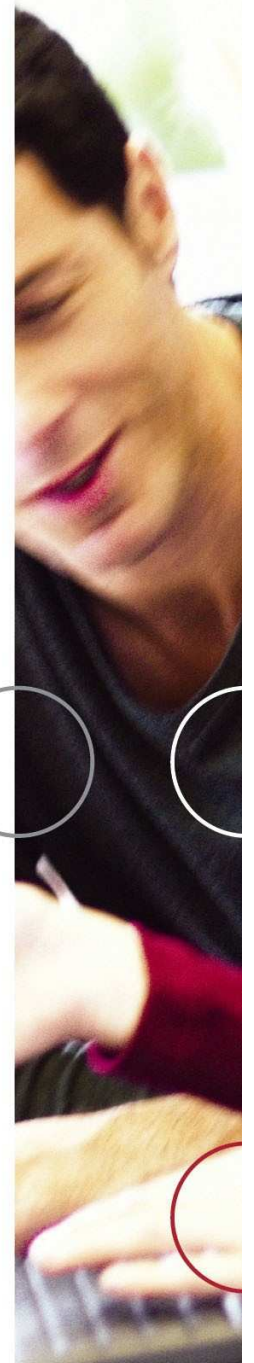
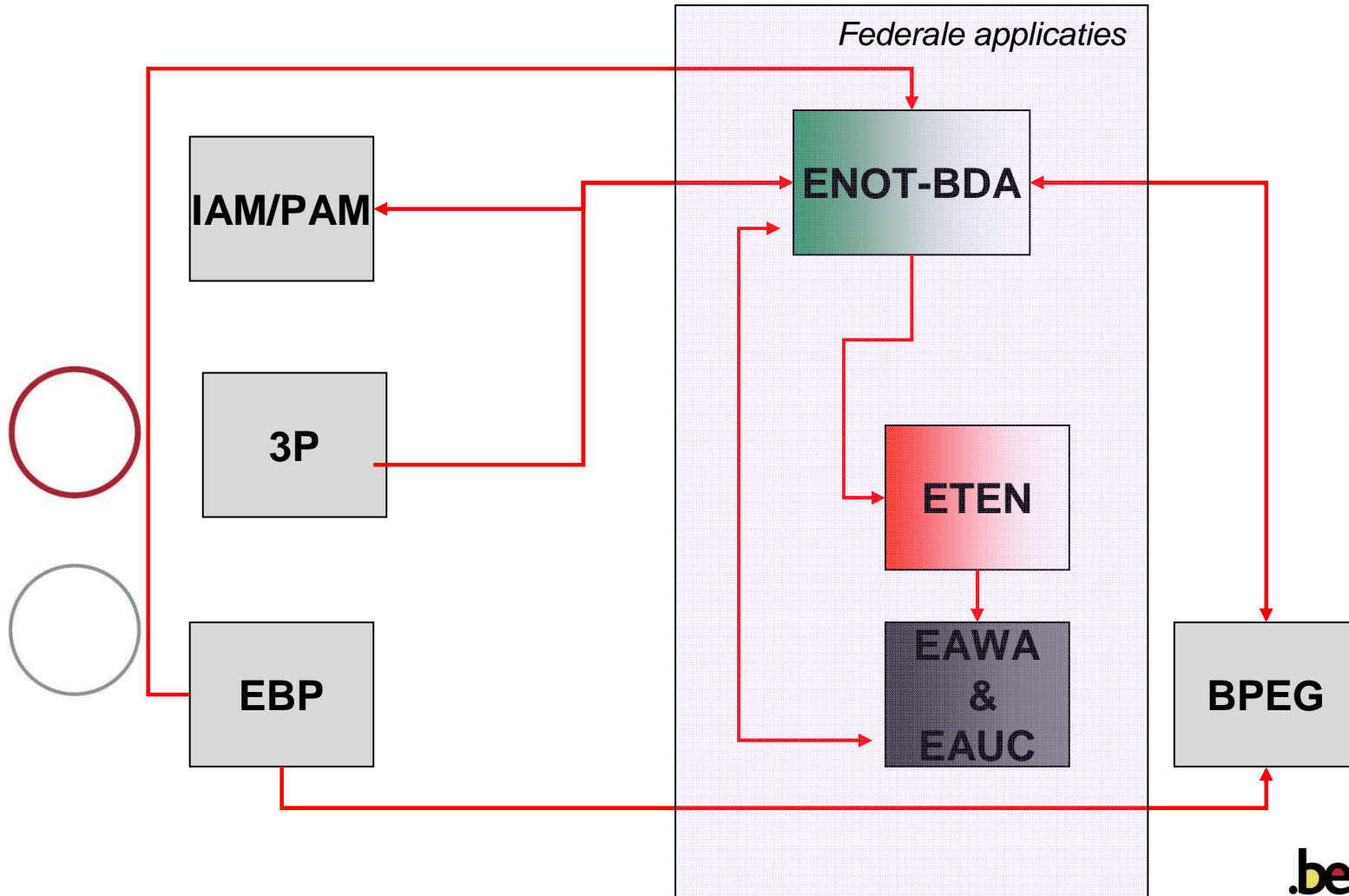



Service public fédéral
Personnel et Organisation

3) Tendensen

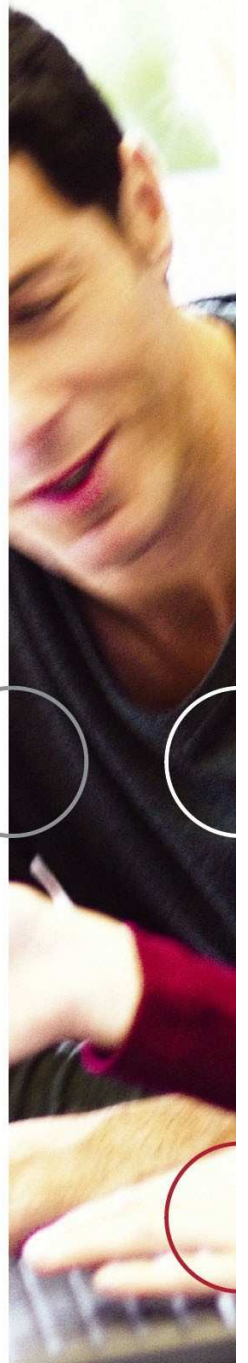
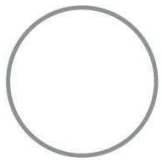

.be



Tendensen (1)

- E-Notification wordt vanaf 1 januari het officieel publicatieplatform en vormt meer en meer een centraal knooppunt in België
- Federaal niveau intensifieert gebruik van e-Procurement
 - Dossier in voorbereiding voor e-Tendering (nieuwe regering)
 - Sommige administraties verplichten nu al het toestaan van elektronische offertes
 - E-Awarding zal in 2011 met pilootprojecten starten

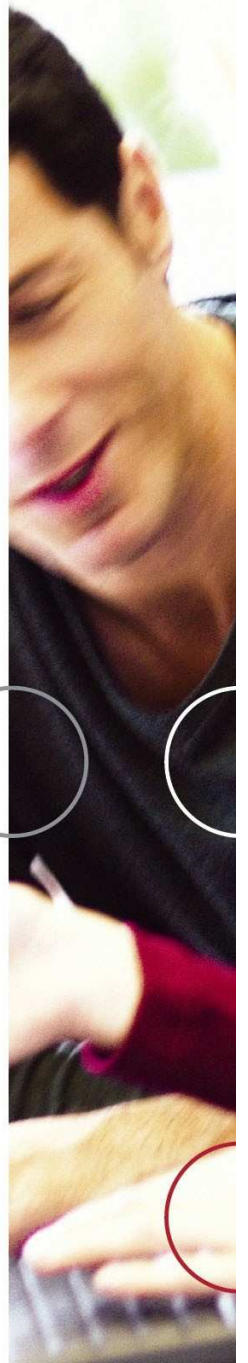
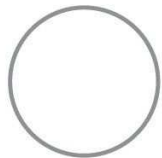



Tendensen (2)

- Andere bestuursniveaus volgen dezelfde trend (of lopen zelfs voorop)
 - Platformen worden gedeeld
 - Gezamenlijke communicatie
 - Streven hetzelfde na

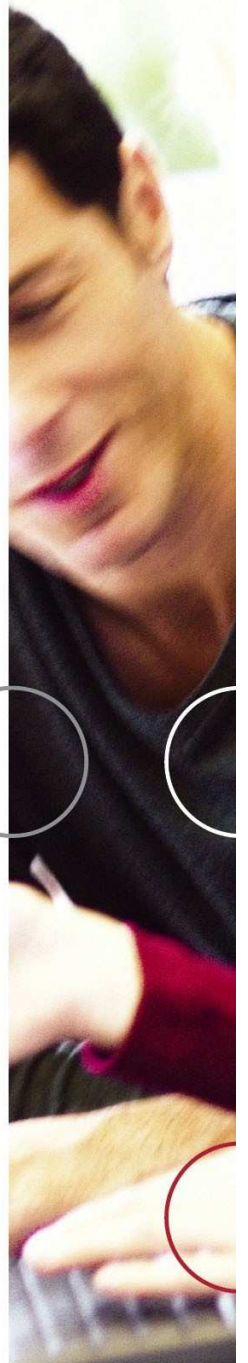
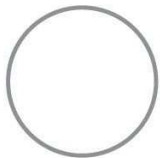



Service public fédéral
Personnel et Organisation

Vragen

- Waldo.vandenbroeck@p-o.belgium.be

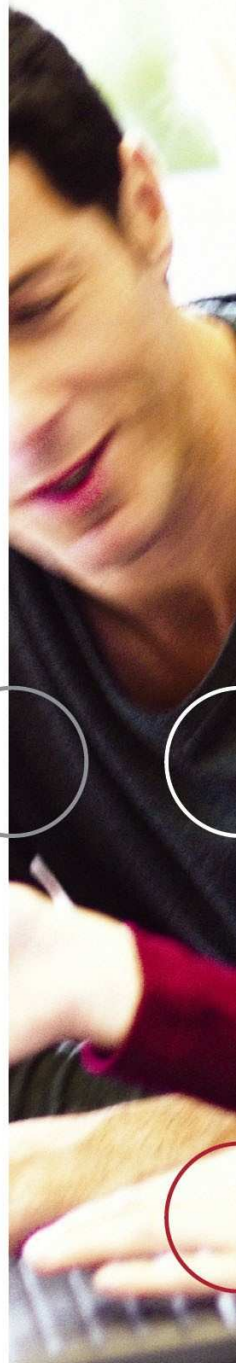
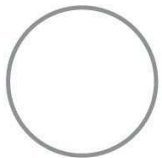

.be